

Passive Equalizer and In-Line Quadsplitter Technologies

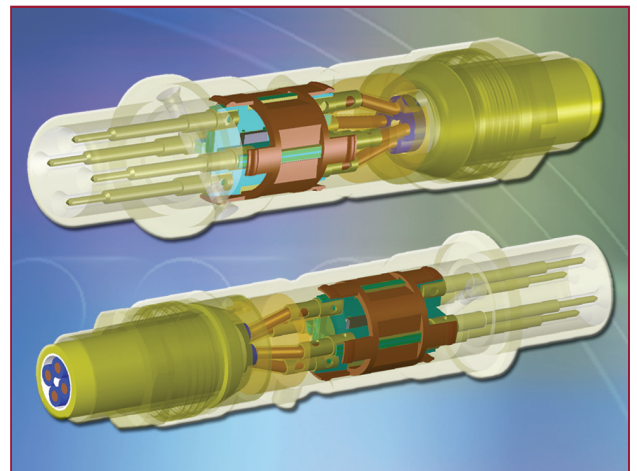

Passive Equalizer Technology Size 8 Twinax/Quadrx Contact

Sabritec's Passive Equalizer contacts operate up to 12.5 GBPS and fits inside a standard Size 8 twinax/quadrax contact cavity for all connector formats. The passive equalizer requires no external power and acts like a high pass filter operating over an extreme temperature range. This compensates for the frequency dependant cable loss and helps to re-open the eye pattern on long cable runs allowing to pass higher data rates, for a given cable length, or extend the length of your cable at existing data rates.

Equalization is an important tool in any digital engineers toolkit. The robust 'invisible to the user' device will extend the reach of high speed digital signals without using any external system power or pc board real estate. It is intended for use in high speed (>2Gb/s) 100 Ohm differential pair interconnect applications. The unique design helps to offset those high frequency losses endemic to high speed digital interconnect paths that are primarily dispersive in nature. As an added benefit of its high pass characteristics, Inter Symbol Interference (ISI) is reduced as well as deterministic jitter. It is invaluable when trying to squeeze the last meter out of a cabling system that had been previously designed for slower data rate signals. Additionally, because of the nature of the equalizer it can be placed anywhere in the transmission path that is convenient to the system designer.

Benefits

- Up to 50% increase in high-speed signaling cable length
- Up to two times increase in data rate for given interconnect length
- Improve the margin at the receiver end for a given signal performance
- Re-use existing wire and cable to drive higher data rate signals
- Entirely passive (no extra power required)
- Self contained in the contact no board real estate used
- Applicable over a wide range of data rates and transmission types
- Decrease the wire gauge size to save weight and improve routability
- Decrease the wire gauge size where there is a high volume of conductors in tight space constraints
- Helps reduce ISI and deterministic jitter
- Can open up the eye pattern over an extended length of 100Ω Twinax/Quadrx Cable
- Temperature range -40°C to +125°





Passive Equalizer/In-Line Quadsplitter

Passive Equalizer Typical Operating Characteristics

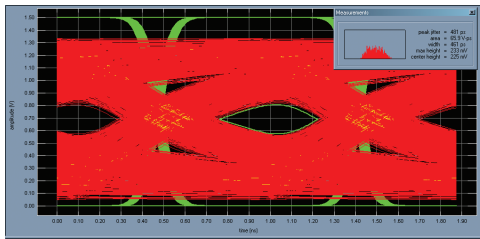

The Eye height and total jitter without Equalization is .225V, 481pS respectively.

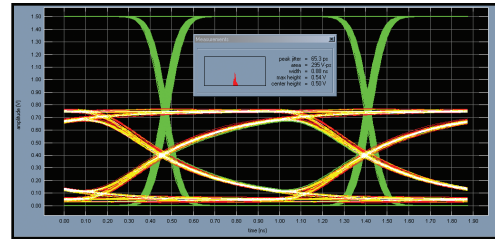

The Eye height and total jitter with Equalization is .500V, 65pS jitter. N.B. An added benefit to maximizing the eye height parameter is that the deterministic jitter also gets significantly reduced, as shown.

In-Line Quadsplitter Contact

Sabritec is now able to offer the best of both worlds with our In-Line Quadsplitter which offers another solution for extending the distance that High Speed signals can be sent over a Quadrx architecture. We can combine the signal integrity of Twinax cables and the connection density of Quadrx contacts by incorporating two 26 AWG Twinax cables into a standard Size 8 Quadrx contact. The resulting cable assembly is about the same size and weight as a 24 AWG Quadrx cable assembly and offers the same flexibility and ease of use.

The In-Line Quadsplitter can be used alone or in conjunction with the In-Line Equalizer. Many customers prefer the connection density and ease of use of Quadrx cables and connectors. Quadrx cables are limited in performance at higher data rates being used today due to the orthogonal construction of the quadrx cable due to crosstalk. Higher losses and frequency drop outs may adversely affect the integrity of the signal as compared to Twinax cables of similar size and construction.

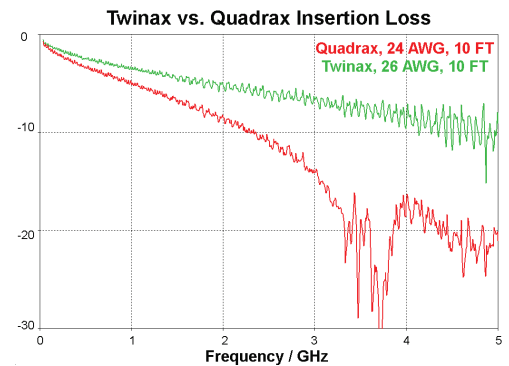

Typical In-Line Equalizer and/or Quadsplitter Packaging in Size 8 Quadrx Contact

*Patent Pending

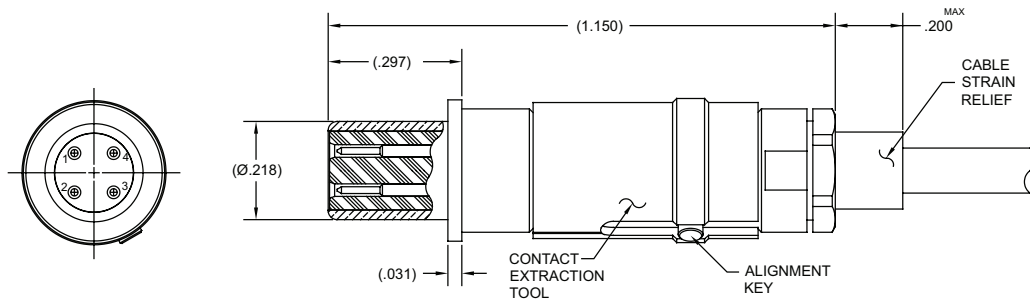

Sample Cable Part Numbers*				
Contact Type	Part Number	Cable Type	Cable	Size
Equalizer	019635-8027	Differential Quad	540-1183-000	24 AWG
Quadsplitter	019635-8030	Differential Twinax	540-1153-000	26 AWG

*Please consult factory for additional cable types and contact configurations.
All connector formats are available for pin/socket Quadrx and Twinax contacts.

Sabritec
17550 Gillette Ave, Irvine
CA 92614, USA

t: +1 (949) 250-1244
f: +1 (949) 250-1009
e: customerservice@sabritec.com

FOR FURTHER INFORMATION VISIT >> www.sabritec.com