

Active Electro-Optical Cable Assembly Transceiver

For Series MIL-DTL-38999



Sabritec's Electro-Optical Cable Assembly Transceiver is a cutting edge fiber optic solution to enhance copper cabling by incorporating the industry's most innovative fiber optic technology advancements. This copper-to-fiber Active Electro-Optical Cable Assembly Transceiver is ideal for high speed network and data communications in harsh environments.

The cable assembly consists of a fiber optic transceiver packaged inside a MIL-DTL-38999 electrical plug connector and can be used with existing boxes with no need to convert the box to fiber optic configuration. This technology creates solutions for issues faced by the demanding wiring applications of the aerospace industry including but not limited to: delivering high bandwidth, long signal propagation and immunity to electronic noise and electromagnetic pulses.

The Electro-Optical Cable Assembly Transceiver features a full electrical interface which is environmentally hardened and designed for use in harsh environments for reliable operation over extended

temperature ranges.

For applications requiring up to 500 meters of link distances, the fiber optic transmitter consists of a 850nm VCSEL laser with multimode fiber optic cable. The receiver consists of an integrated 850nm PIN-Preamplifier. For those requiring up to 10km of link distances, the fiber optic transmitter consists of a 1310nm Fabry Perot laser with single-mode fiber optic cable. The receiver section consists of an integrated 1310nm PIN-Preamplifier.

Transmitter inputs are differential LVPECL compatible and receiver outputs are differential CML receiver has a LVTTTL compatible signal detect output to indicate the presence of valid data at the input of the fiber optic receiver.

The following are the versions that can be offered:

Active cable with 1 fiber optic module: 1 transceiver, or 2 transmitters, or 2 receivers.

Active cable with 2 fiber optic modules: 2 transceivers, or 4 transmitters, or 4 receivers.

In addition to the above combination we can offer straight backshell or right angle backshell for the active cable.

- Full electrical interface removes all limitations
- Operating temperature range of -40°C to +85°C
- Significant weight reduction
- Enhanced signal integrity
- Intermateable with standard MIL-DTL-38999 electrical receptacle per MIL-STD-1560

Active Electro-Optical Cable Assembly

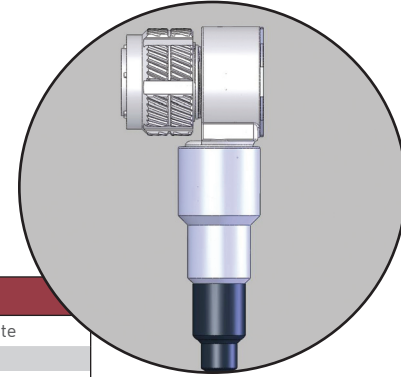

Absolute Maximum Ratings				
Parameters	Symbol	Minimum	Maximum	Unit
Power Supply Voltage	V _{CC}	-0.3	4.0	V
Storage Temperature	T _S	-55	100	°C
Operating Case Temperature	T _C	-40	85	°C
RX Output Current	I _O		50	mA
TX Output Current	V _D		2.2	V
Cable Minimum Bend Radius	R _C	16		mm

Note: Minimum cable bend radius for 2mm jacketed cable

Operating Conditions						
Parameters	Symbol	Minimum	Typical	Maximum	Unit	Note
Power Supply Voltage	V _{CC}	3.135	3.3	3.465	V	
Operating Case Temperature	T _S	-40		85	°C	
Total Supply Current	I _{CC}		190	240	mA	850nm link
			240	310	mA	1310nm link
Total Power Dissipation	P _{DIS}		.62	.83	W	850nm link
			.79	.79	W	1310nm link

Transmitter						
Supply Current	I _{CC} TX		85	120	mA	850nm link
			120	160	mA	1310nm link
Input Differential Impedance	R _{IN}		100		Ω	Differential
Input Differential Voltage Level	V _{IN} pp	500		2400	mVp-p	AC-Coupled Differential
Transmit Disable Voltage	TX _{DIS}	2.0		V _{CC}	V	
Transmit Enable Voltage	TX _{EN}	V _{EE}		0.8	V	

Receiver						
Supply Current	I _{CC} RX		90	120	mA	850nm link
			120	150	mA	1310nm link
Data Output Impedance			50		Ω	Single-ended
Output Differential Voltage Level (CML)	V _{OUT} pp	600		940	mVp-p	AC-Coupled Differential
Signal Detect Assert	SD _{NORM}	2.4		V _{CC}	V	
Signal Detect De-Assert	SD _{FAULT}	V _{EE}		V _{EE} +0.5	V	

Optical Characteristics						
Parameters	Symbol	Minimum	Typical	Maximum	Unit	Note
Optical Power (50/125 MMF)	P _{OUT}	-9		-3	dBm	850nm link
		-5		1	dBm	1310nm link
Optical Wavelength	λ	830	850	860	nm	850nm Link
		1285	1310	1343	nm	1310nm Link
Spectral Width	σ			0.85	nm	850nm Link
				4	nm	1310nm Link
Optical Modulation Amplitude	O _{MA} TX	196			μW	850nm Link, 100 Mb/s - 2.125Gb/s
		247			μW	850nm Link, 2.125 Gb/s - 4.25 Gb/s
Optical Modulation Amplitude	O _{MA} TX	210			μW	1310nm Link
Extinction Ratio	ER		9		dB	1310nm Link

Receiver						
Receiver Sensitivity	RX _{SENS}			-18	dBm	850nm Link, 100Mb/s - 2.125Gb/s
				-15		850nm Link, 2.125 Gb/s - 4.25 Gb/s
Receiver Sensitivity	RX _{SENS}			-21	dBm	1310nm Link, 1.25Gb/s
Maximum Receive Power	RX _{MAX}			0	dBm	850nm Link
Maximum Receive Power	RX _{MAX}			+5	dBm	1310nm Link, 1.25Gb/s
Signal Detect Assert	SD _A			-17	dBm	850nm Link
Signal Detect De-Assert	SD _D	-31			dBm	850nm Link
Signal Detect Hysteresis		1.5			dB	850nm Link
Signal Detect Assert	SD _A			-25	dBm	1310nm Link
Signal Detect De-Assert	SD _D	-32			dBm	1310nm Link
Signal Detect Hysteresis		1.5			dB	1310nm Link

Sabritec
 17550 Gillette Avenue
 Irvine CA 92614, USA
 Phone: +1 (949) 250-1244
 Fax: +1 (949) 250-1009